

## Delta Element Steam Traps

Model: DM25

CRN: Canadian Registration Number Available

**FOR HIGH PRESSURE DRIPLEG PROCESS SERVICES**

**3 Year No Live Steam Loss Guarantee**

For use on a steam main dripleg and critical tracing services

- **Maximum differential pressure** - 320 psi (22,1 bar)
- **Easy maintenance** – traps are in-line repairable when isolated from live steam system and can be up and running again in minutes
- **Single blade element** – offers long-term, trouble-free service because it's not prone to dirt build-up as encountered with many other bimetal designs
- **Stainless Steel internals** – leads to longer service life since materials are highly resistant to fatigue and corrosion
- **Modulating discharge** – automatically adjusts to operating pressure and load
- **Continuous air and CO2 venting** – maximizes heat transfer while minimizing corrosion

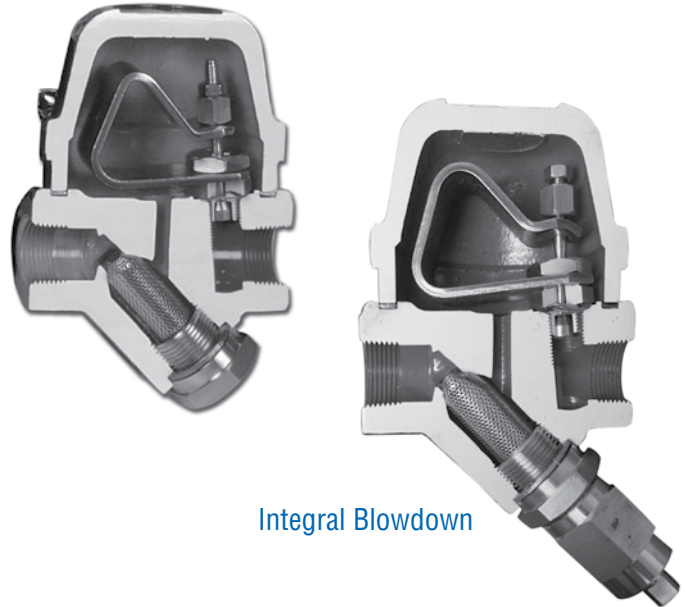

Integral Blowdown

### ORDERING SCHEMATIC

MODEL					6	7	8
D	M	0	2	5			

6	SIZE
2	1/2"
3	3/4"

7	CONNECTIONS
1	NPT
2	FSW
3	150# Flange
4	300# Flange
5	600# Flange
8	BSPT
9	BSPP

8	SPECIALITIES
0	None
1	DTC
3	Integral Blowdown



**BESTOBELLSTEAM**

A Division of  
Richards Industrials  
3170 Wasson Road  
Cincinnati, OH 45209

phone. 513.533.5600

steam@richardsind.com  
www.bestobellsteamtraps.com

**FOR STEAM MAIN DRIPLEG AND CRITICAL TRACING**
**SPECIFICATIONS**
**Maximum Differential Pressure:** 320 psi (22,1 bar)

**Maximum Allowable Pressure:** 750 psig (51,7 bar)

**Maximum Allowable Temperature:** 650°F (343°C)

**MATERIALS**
**Body & Cover:** Forged Carbon Steel A105

**Valve Seat:** 303 SST

**Stem:** 17-4 SST

**Bi-Metal:** Stainless Steel NiCr

**Strainer:** Stainless Steel 304

**Bolts:** ASTM-A193, B7

**Gasket:** Flexible Graphite

**Options:** Double Threaded Strainer Cap (DTC) for blowdown, Double Threaded Strainer Cap (DTC) for blowdown valve attachment; selection of integral blowdown valves

**Mounting:** From horizontal to vertical (see Installation & Maintenance Instructions). Self-Draining and freeze-resistant when mounted in vertical position.

**Line Sizes:** 1/2", 3/4"

**End Connections:** NPT, BSPT, BSPP, SW, Raised Face Flanged (ANSI 105#, 300#, 600# or DIN)

**BENEFITS OF THE DELTA ELEMENT DESIGN**

The combination of thermostatic and thermodynamic forces make the Bestobell Delta Element steam traps more than a match for the steam curve. They are designed (and factory pre-set) to match virtually all of your applications and plant requirements - whether for tracing, dripleg, process, heating, or even high pressure service. Following the steam curve is the key to efficient steam trap performance as it provides you with the most energy efficient operation. The balanced pressure control operation of the Bestobell Delta Element trap matches the steam curve and allows efficient trap operation over wide pressure ranges.

**CAPACITY CHARTS: CONDENSATE CAPACITY AT OPERATING PRESSURE**

Model DM25		50	100	120	150	200 (13,8)	250	300	320 (22,1)
Size	Operating Pressure, psi (bar)	(3,4)	(6,9)	(8,3)	(10,3)		(17,2)	(20,7)	
1/2"	Cold start-up, lbs/hr	1500	1950	2050	2200	2400	2600	2700	2800
	Hot (dripleg), lbs/hr	70	80	85	90	100	105	110	110
3/4"	Cold start-up, kgs/hr	680	885	930	998	1090	1180	1220	1270
	Hot (dripleg), kgs/hr	32	36	39	41	45	48	50	50

Note: Flow rates are based on discharge to atmospheric pressure, valid for back pressure up to 20% of inlet pressure. Higher back pressure requires reset of control element to obtain these capacities. Consult factory for details.

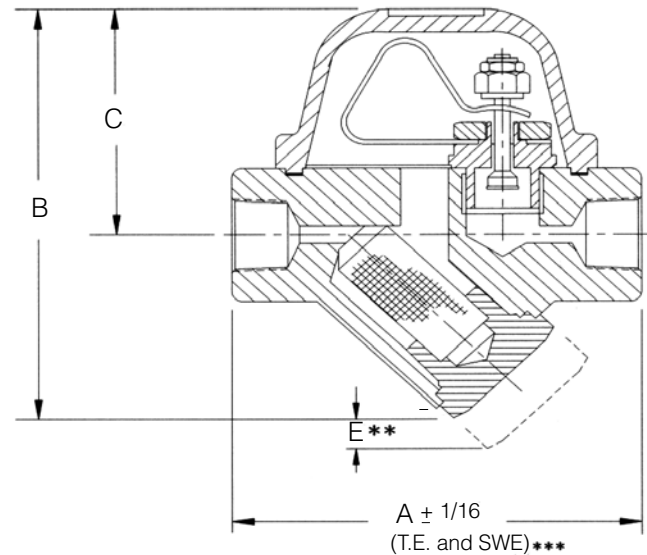
**MODEL DM25 SERIES DIMENSIONS**

Model DM25						
1/2"-3/4"	A	B	C	D	E	Wt
inches	4.00	5.00	3.25	3.125	2.25	5.5 lbs
mm	102	127	83	79	57	2,5 kg

Notes: dimension D is overall width; \*\* dimension E is withdrawal distance for strainer, \*\*\*dimensions shown are for threaded or socket weld ends, contact factory for other dimensions

